

GEN PRECISION

SEP 26 1967

KEARFOTT AEROSPACE DIGITAL

COMPUTERS

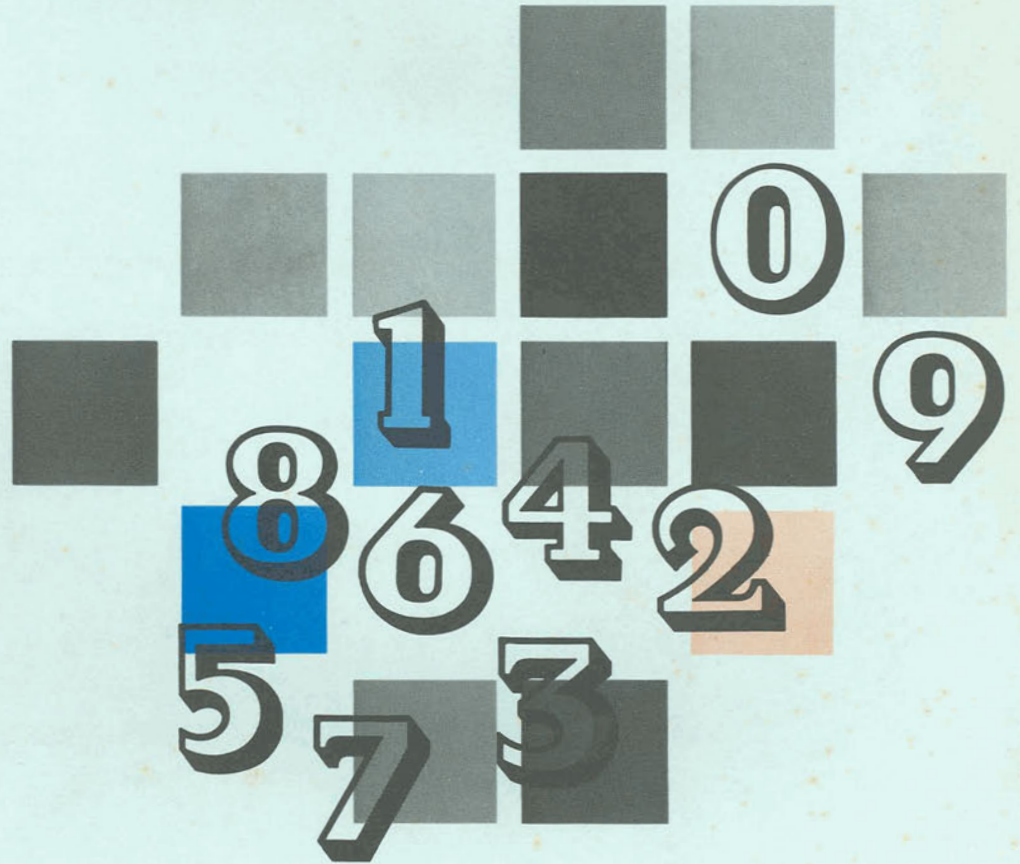

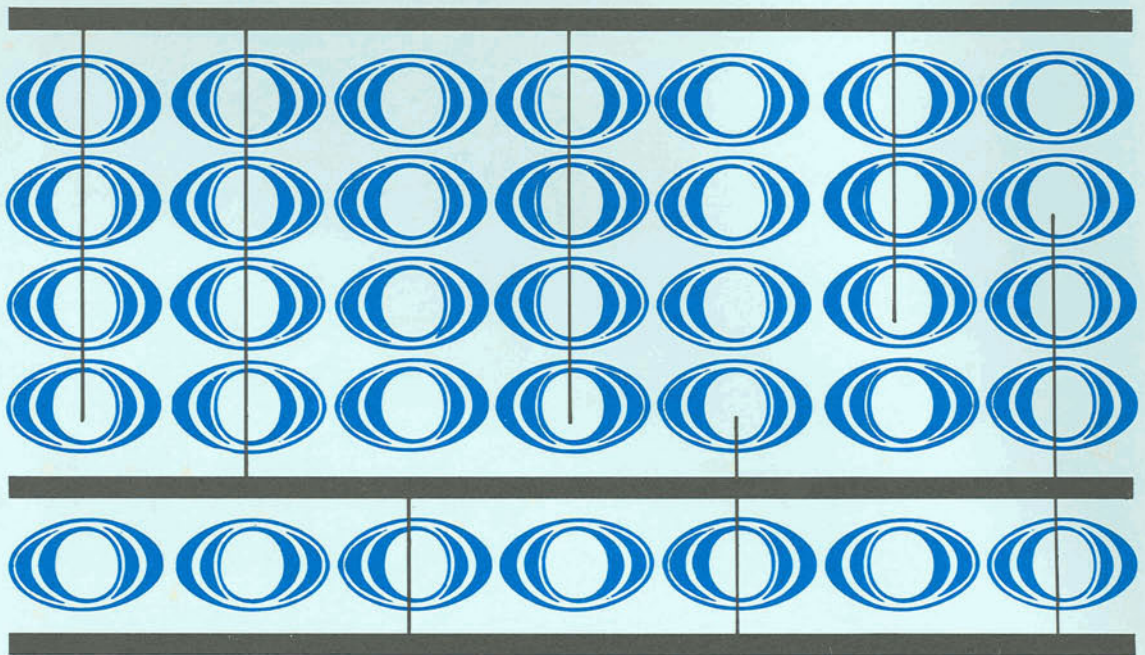

CONTENTS

| | |
|---|----|
| GPK-20 Computer | 4 |
| Micro-Minac Computer | 6 |
| GPK-10 Low-Cost GP Digital Computer | 8 |
| GPK-33 Atlas/Centaur Navigation Computer | 12 |
| AN/ASN-24(V) Airborne/Aerospace Computer Set | 14 |
| AN/ASN-24(G) Airborne/Aerospace Computer Set | 18 |
| L-90 Series General-Purpose Digital Computers | 20 |

The demands for high-performance computers which can squeeze into small aircraft and missile systems spurred Kearfott's progressive development of digital computers meeting requirements for size, function, accuracy, and reliability.

Versatile general-purpose digital computers designed for micro-second pinpoint navigation — with or without help from pilots or navigators — are hardware realities at Kearfott, and have consistently proved their mettle wherever they have flown.

A wide variety of digital computers demonstrating Kearfott's specialized capability underscores the imaginative engineering concepts and solutions Kearfott employs to create computer equipment having exceptional adaptability.

Kearfott, the largest airborne computer producer in the United States, is thoroughly experienced in the design and production of computers having solid state, drum, and disc type memories. Woven memory techniques applicable to computer technology are also under development.

For special applications, Kearfott general purpose computers, incorporating small digital differential analyzer techniques, have been flight tested. These permit speedy solution of certain critical problems while preserving normal routine speed for ordinary requirements.

GPK-20 Computer

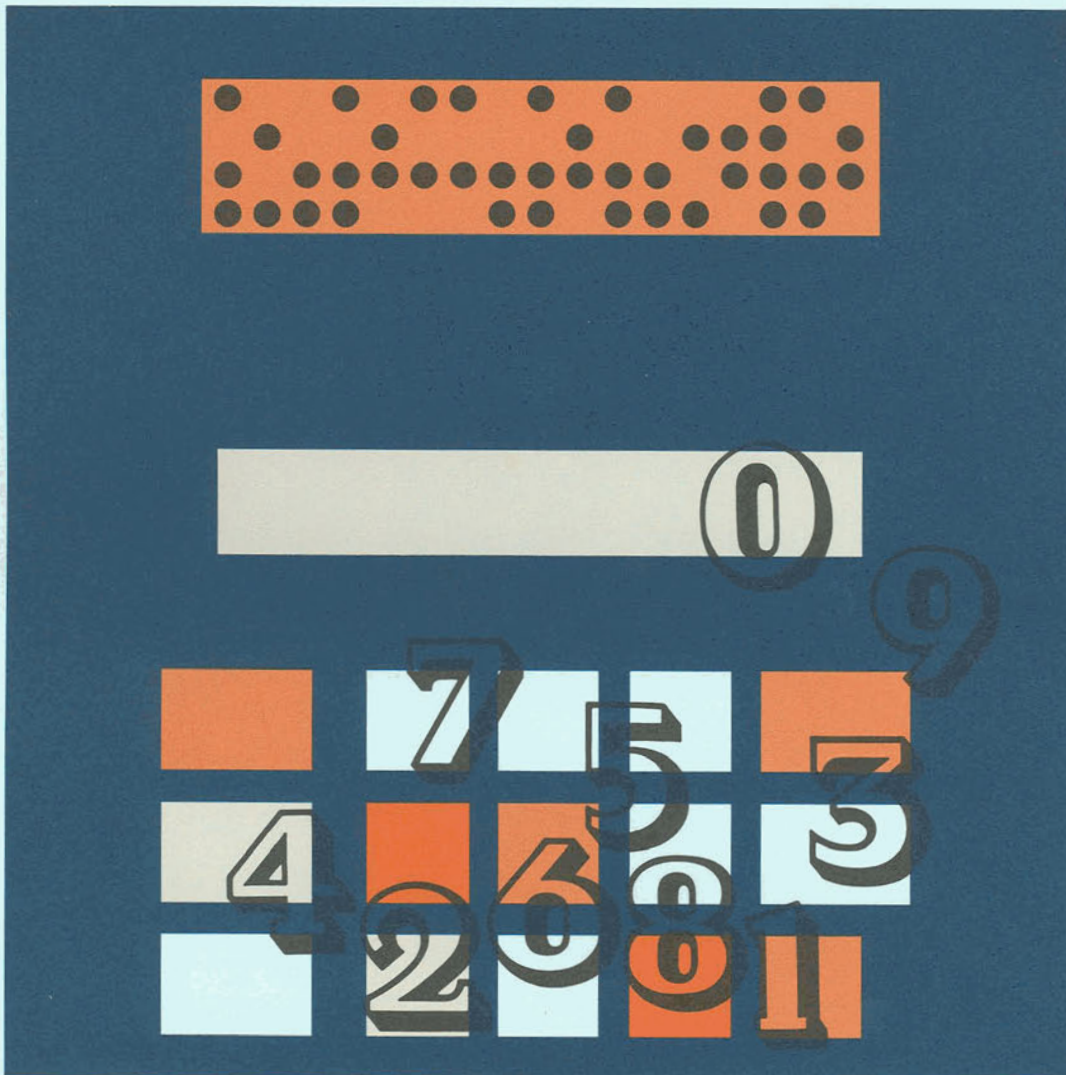

A general-purpose digital machine for navigation and guidance functions and weapons delivery in military aircraft. A modular random-access solid-state core memory, arithmetic and control sections, analog to digital signal conversion, and a power supply are all contained in a single unit which incorporates self-protection features guarding against inadvertent memory loss. Its memory, operating at a 4-microsecond cycle time and a 1-microsecond access time, may be expanded without redesigning non-destructive readout (wired program) or writeable configuration combinations.

Solid-state components, including micro-electronic integrated circuits, are used exclusively in the conversion segment, which can condition the analog interface entirely within the computer. This element converts both input and output data, with no degradation of system information, to accuracies up to 11 bits.

The power supply, designed to meet MIL-STD-704, Category B, includes controls protecting the computer from input and regulated output conditions that are unacceptable for orderly computer shutdown and data preservation.

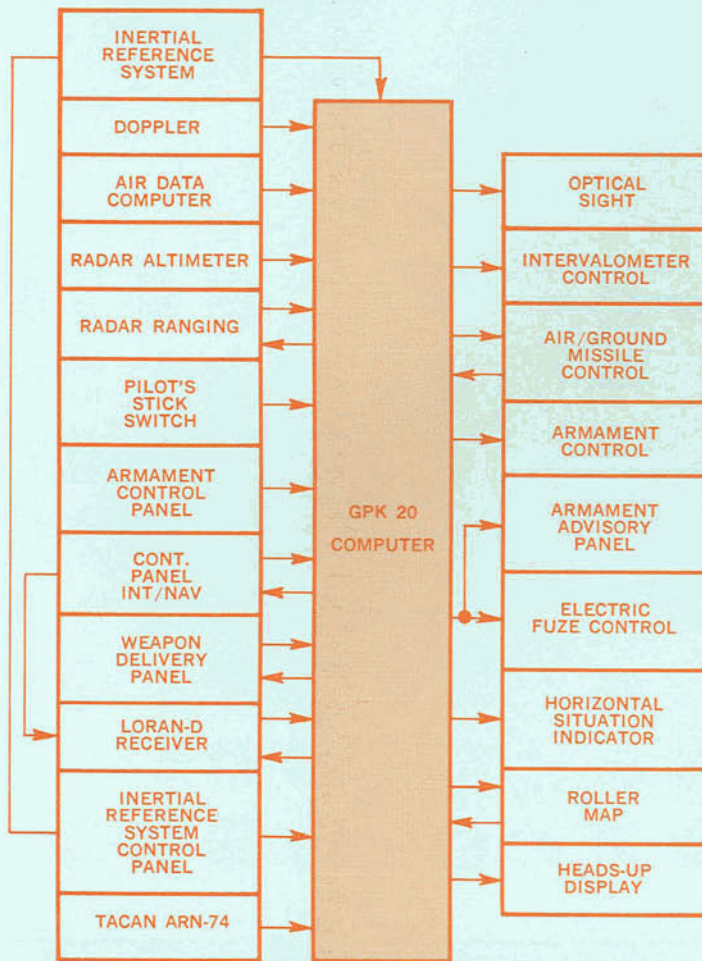

WEAPONS DELIVERY APPLICATION

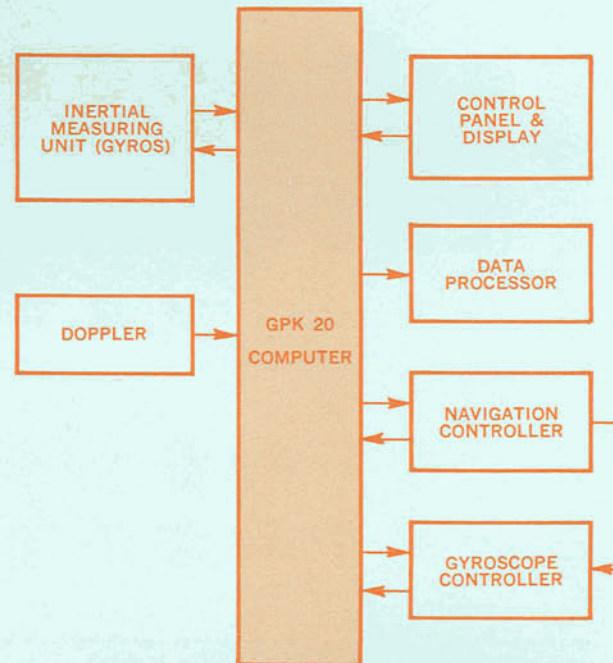
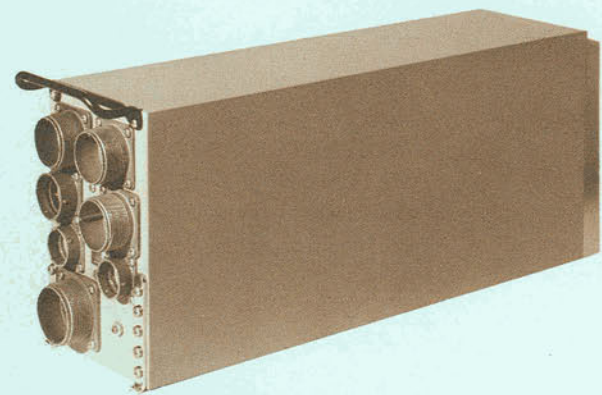

INERTIAL NAVIGATION APPLICATION

CHARACTERISTICS

| | |
|---------------------------------|---|
| Number of Orders | 32 (including double precision and square root) |
| Memory Type | Random access core (NDRO wired or writeable in any combination) |
| Memory Cycle Time | 4 microsec |
| Memory Access Time | 1 microsec |
| Memory Capacity | 4,096 to 16,384 X 10 bits parallel |
| Operation Times (with accesses) | Add: 20 microsec.; Multiply: 100 microsec. |
| Clock Rate | 1 MHz |
| Data Word Size | 20 bits in 5-bit bytes |
| Digital Input/Output Control | Programmable 16-order set |
| Input/Output | Discrete inputs (20/channel) Discrete outputs (20/channel) Pulse train inputs (20 Kc max. rate implemented) Pulse train outputs (under program control) Serial inputs (10 Kc and 40 Kc implemented) Serial outputs (10 Kc and 40 Kc implemented) Parallel inputs (20 bits/channel) Parallel outputs (20 bits/channel) Synchro-digital conversion (10 msec, avg. time, 13 bits) Digital-synchro conversion (1 part in 8192) |
| Digital Logic | 100% use of DTL microelectronic integrated circuits |
| Size | 612 cu. in. |
| Weight | 25 lbs. |

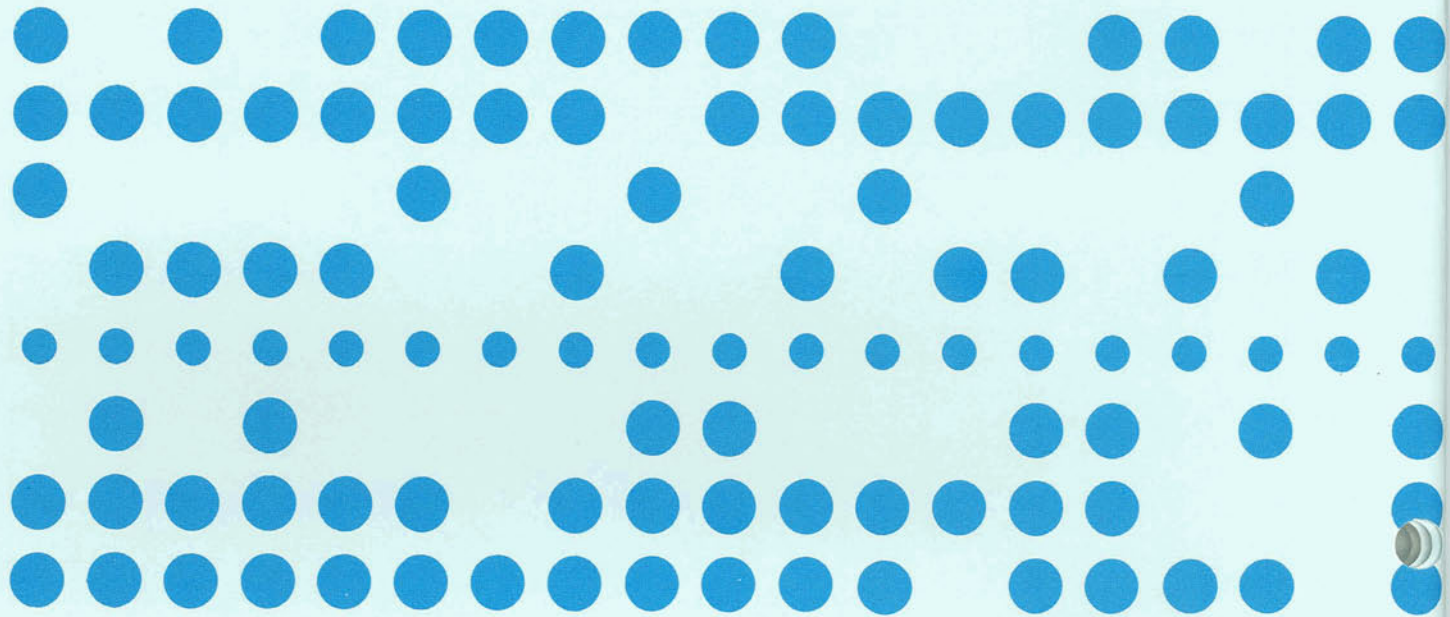

Micro-Minac Computer

A significant advancement in the development of small, lightweight, low-cost navigational computers, MICRO-MINAC replaces an earlier analog computer without affecting associated system equipment or cabling. Consisting of a programmable solid-state computer element together with a separate MINAC control/display unit, this airborne computer set has a number of desirable capabilities built into it to enhance its use in tactical missions. The computer segment contains synchro-to-digital converters, digital-to-analog converters, a digital processor, and a power supply. It accepts true air speed, drift angle, ground speed, and magnetic heading inputs from Doppler radar, a magnetic compass, and an air-speed sensor to provide relative ground track, relative bearing to destination, and distance-to-go outputs to a

Bearing-Distance-Heading Indicator (BDHI). Doppler-mode-computed present position, wind direction and velocity, together with marked target coordinates are selected by the operator for readout on the computer set's accompanying Control/Display panel. All computer outputs can be made available to other devices.

Temperature-stable ferrite cores in the computer's memory, wired for coincident-current operation, are organized in a byte array, a portion of which is reserved for such variable-data storage as destinations, present positions, etc. Remaining words storing fixed data, constants, program, tabular data, etc. are read out nondestructively (NDRO), a feature accomplished by wiring this information into the cores for automatic restoration after each readout.



CHARACTERISTICS

| | |
|-------------------------|--|
| Memory Cores | 10,240 total |
| Memory Array Capacity | 2,048 bytes (5 bits each) |
| Clock Rate | 1 MHz, 4 phase |
| Word Length | 20 bits |
| Digital Output Channels | 1 Serial data channel |
| Flatpacks | 600 |
| A/D Conversion | 4 synchro input channels 5 torque transmitter channels for BDHI |

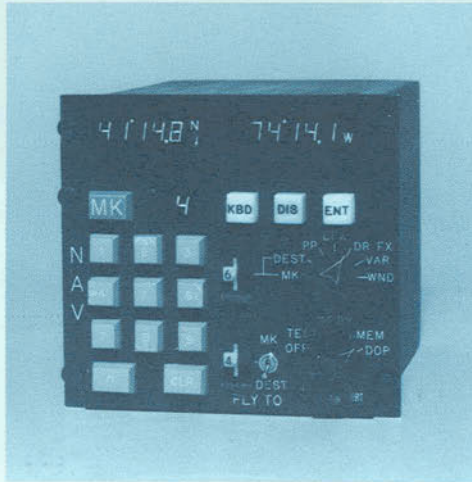

FEATURES

- Small, lightweight, low-cost airborne navigation computer
- Computes Doppler navigation, present position, course, distance
- Outputs compatible with a variety of devices, systems
- Combines DRO and NDRO memory
- A whole-number general-purpose computer incorporating special coordinate rotation algorithm
- All solid-state computer element
- Self-contained power supply
- Separate control/display — time-shared position/destination
- Self-testing

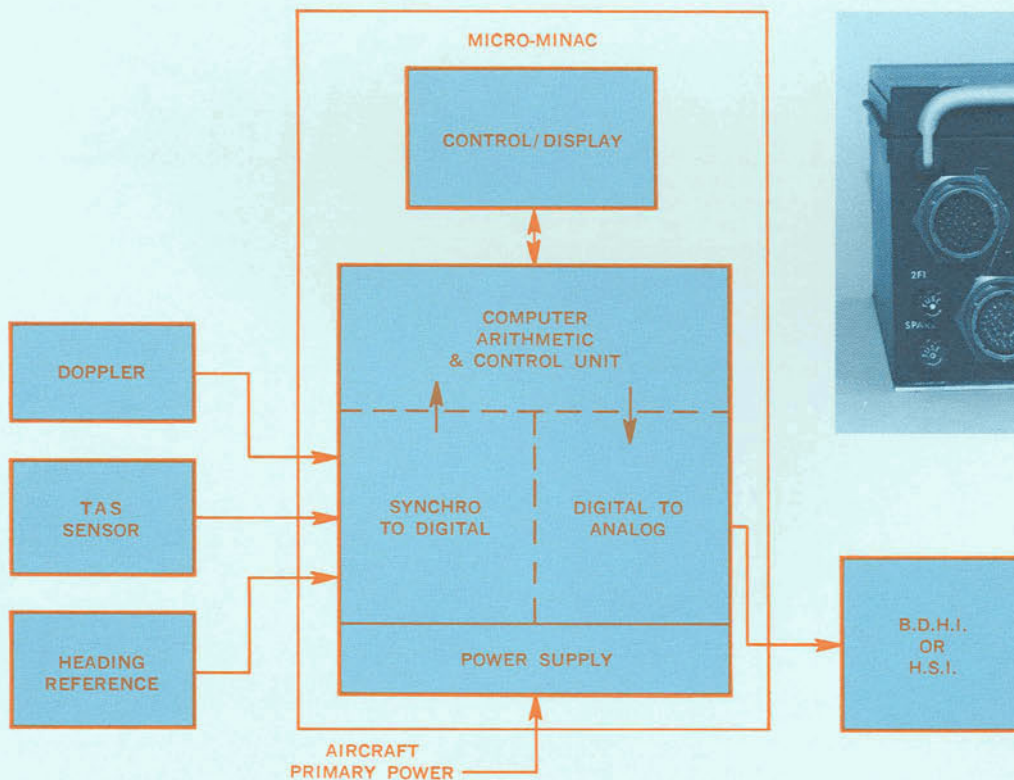

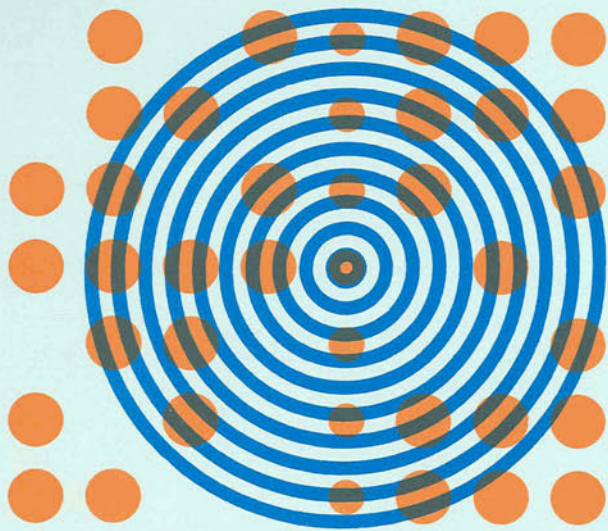

GPK-10

Low Cost

GP Digital

Computer

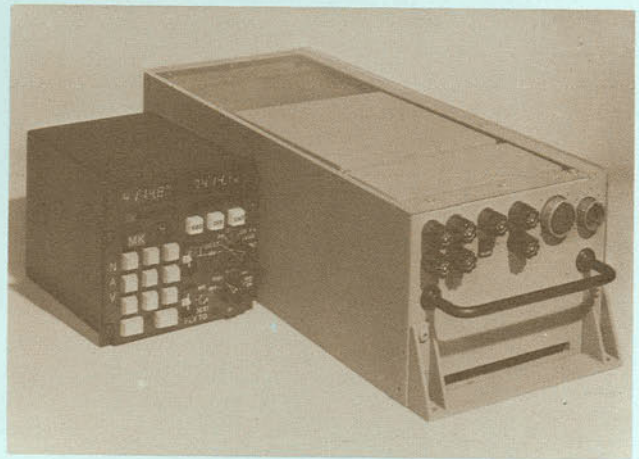

A whole-number microelectronic computer for central navigation, guidance, and real-time data processing applications aboard aircraft, missiles, and spacecraft, GPK-10 uses minimal serial logic and a simple, modularly expandable Librascope disc memory whose capacity can be extended by additional head modules. Characterized by a flexible digital interface and simple arithmetic structure, this computer can handle a variety of input/output combinations to satisfy requirements of many applications. Its self-contained power supply incorporates a high-frequency switching regulator contributing to high efficiency and minimal size and weight. Immune to line voltage transients, this power supply includes a standby circuit providing temporary power during voltage transfer or other extreme voltage transients.

Conversion equipment, either A/D or D/A, and control/display elements are Kearfott-produced and precisely matched to the particular application involved, and may be obtained in a variety of types and configurations — all suited to marriage with GPK-10.

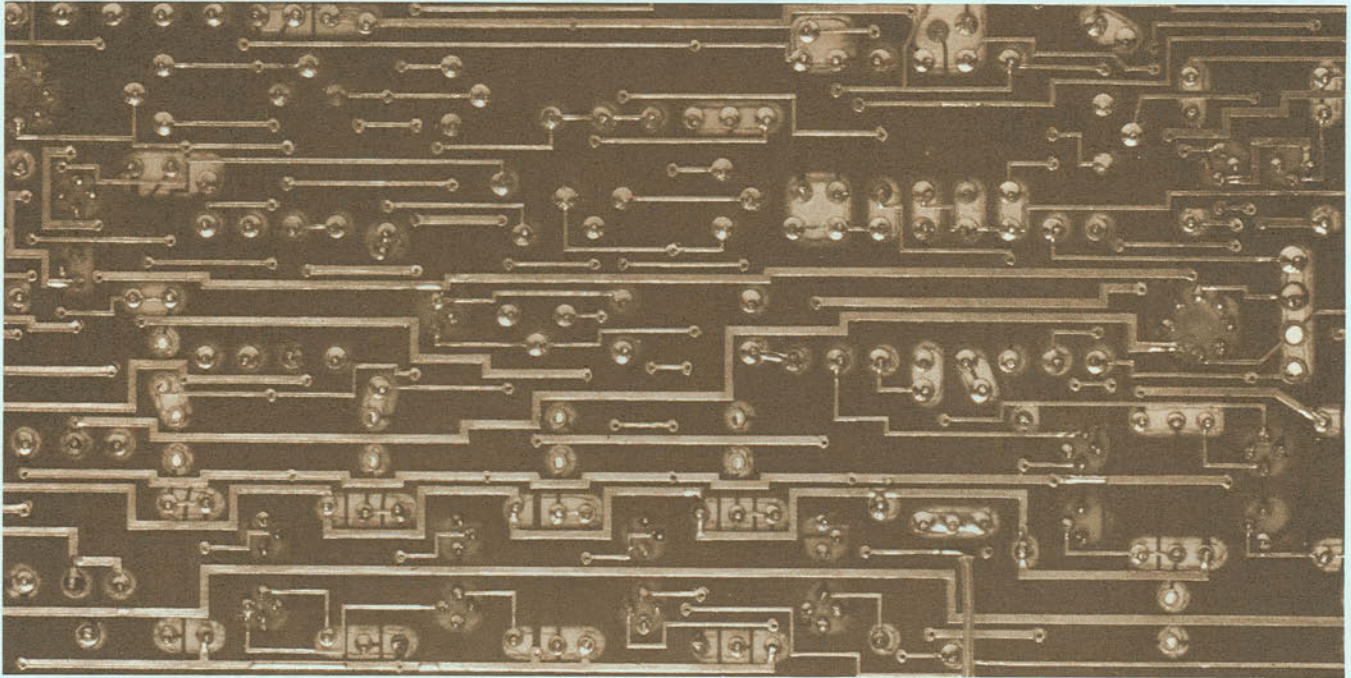

CHARACTERISTICS

| | | |
|---|--|-------------|
| Memory Capacity | 16,360 X 32 bits in 3,072-word modules (Permanent) 1,536 X 32 bits (Temporary) | |
| Arithmetic Unit Clock Rate Word Length Digital Input Channels | 1 MHz 31 bits + sign 11 pulse rate channels 1 serial data channel 8 priority-interrupt channels 12 encoder channels 124 parallel data channels (16 bits) 64 discretes | |
| Digital Output Channels | 3 pulse rate channels 16 parallel data channels (16 bits) 32 discretes 12 encoder channels 1 serial data channel | |
| Power Supply | Self-contained. Meets MIL-STD 704 | |
| Operation Times (including memory readouts) | ADD 117 microseconds SUBTRACT 117 microseconds MULTIPLY 1025 microseconds DIVIDE 1055 microseconds SQUARE ROOT 1024 microseconds | |
| Auxiliary Hi-Speed Incremental Processor Characteristics (compatible with incremental accelerometers and gyro pulse torquing) | | |
| Integration Rate | 533 solutions/second | |
| Asynchronous Pulse Inputs | 30 KHz | |
| Pulse Outputs | 500 Hz | |
| Number of Words | 64 | |
| Environmental Characteristics | Meets MIL-E-5400H, Class II | |
| Memory Characteristics | | |
| Single Disc | 6.5 in. diameter | |
| Speed | 8,000 rpm | |
| Permanent Storage Tracks | 72 | |
| Permanent Memory Capacity | 608,256 total bits | |
| Recirculators | 19 | |
| Typical Recirculators (n = 33 bits) | Track 15 (2 read heads) | 16n and 64n |
| | Track 14 | 16n |
| | Track 17 | 126n |
| | Track 19 | 210n |
| Clock Rate | 1.07 MHz, (including slip) | |
| Words/Track | 256 | |
| Clock Tracks | 1 + 1 spare | |
| Sector Address Tracks | 1 + 1 spare | |

APPLICATIONS AND PROGRAMMING

- Aircraft navigation and control
- Missile and spacecraft guidance and control
- Recon aircraft camera control
- Fuel management, airdrop
- In-flight subsystem monitoring
- Program software for GPK-10 — air mass navigation, Doppler, Doppler-inertial, pure inertial — with LORAN, TACAN, or celestial up-dating



FEATURES . . .

COMPUTER

- Contains disc memory, memory electronics, logic electronics for arithmetic/control/input-output operation, and power supply
- Fixed-point fractional data words; negative numbers in 2's complement form
- All logic circuits DTL; MOS dynamic shift registers
- Packaged in 3/4 ATR ARINC chassis
- Flexible — adaptable to many applications

MEMORY

- Consists of hermetically sealed disc assembly (in He/N atmosphere), and memory electronics
- Highly reliable, NDRO
- Inherent simplicity reduces cost and complexity compared to solid-state core memories, increases MTBF
- Flying-head design prevents excessive disc and head wear; head "floats" on air film as disc rotates
- Memory electronics in 2 subassemblies — (1) pre-amplifiers and head selection, and (2) read and write amplifiers. Performs low-level selection, packageable with read heads as basic expandable assembly. Read and write electronics separately packaged as plug-in modules needing no modification for expanded memory

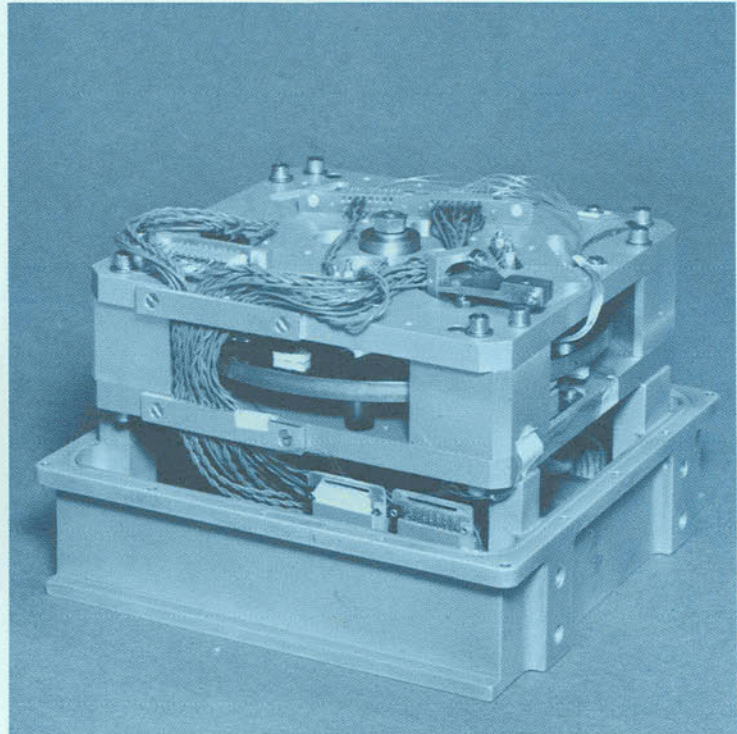

CONVERSION AND CONTROL/DISPLAY UNITS

- Compatible A/D and D/A conversion and control/display units tailored to application are now available
- Control/display panels may use conventional servoed counters, stepper-driven counters, incandescent displays, electroluminescent alpha/numeric displays, manual or electromechanical slewing inputs, data insertion keyboards — all designed and built in quantity by Kearfott

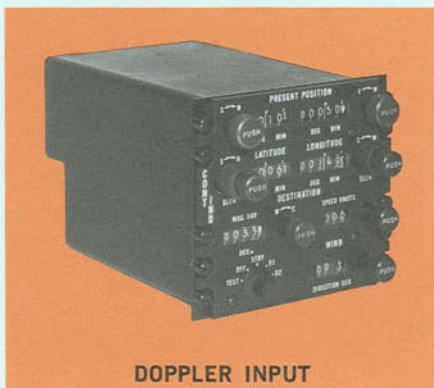

DOPPLER INPUT

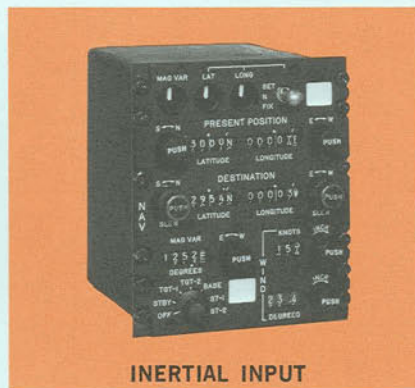

INERTIAL INPUT

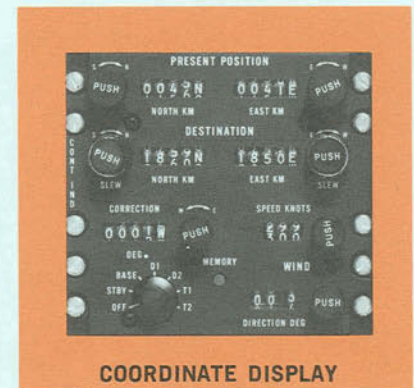

COORDINATE DISPLAY

AUXILIARY CIRCUIT WAVE FORMS

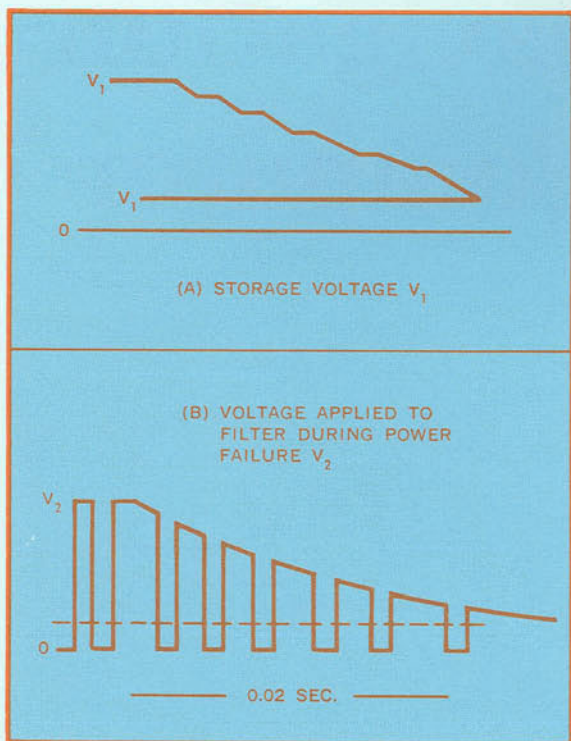

POWER SUPPLY

- Integrally mounted to computer chassis
- Rectifies, filters to 2% regulation from 115-volt, 400 Hz, 3 ϕ aircraft power
- Auxiliary circuit permits uninterrupted operation for full 0.02 second power loss

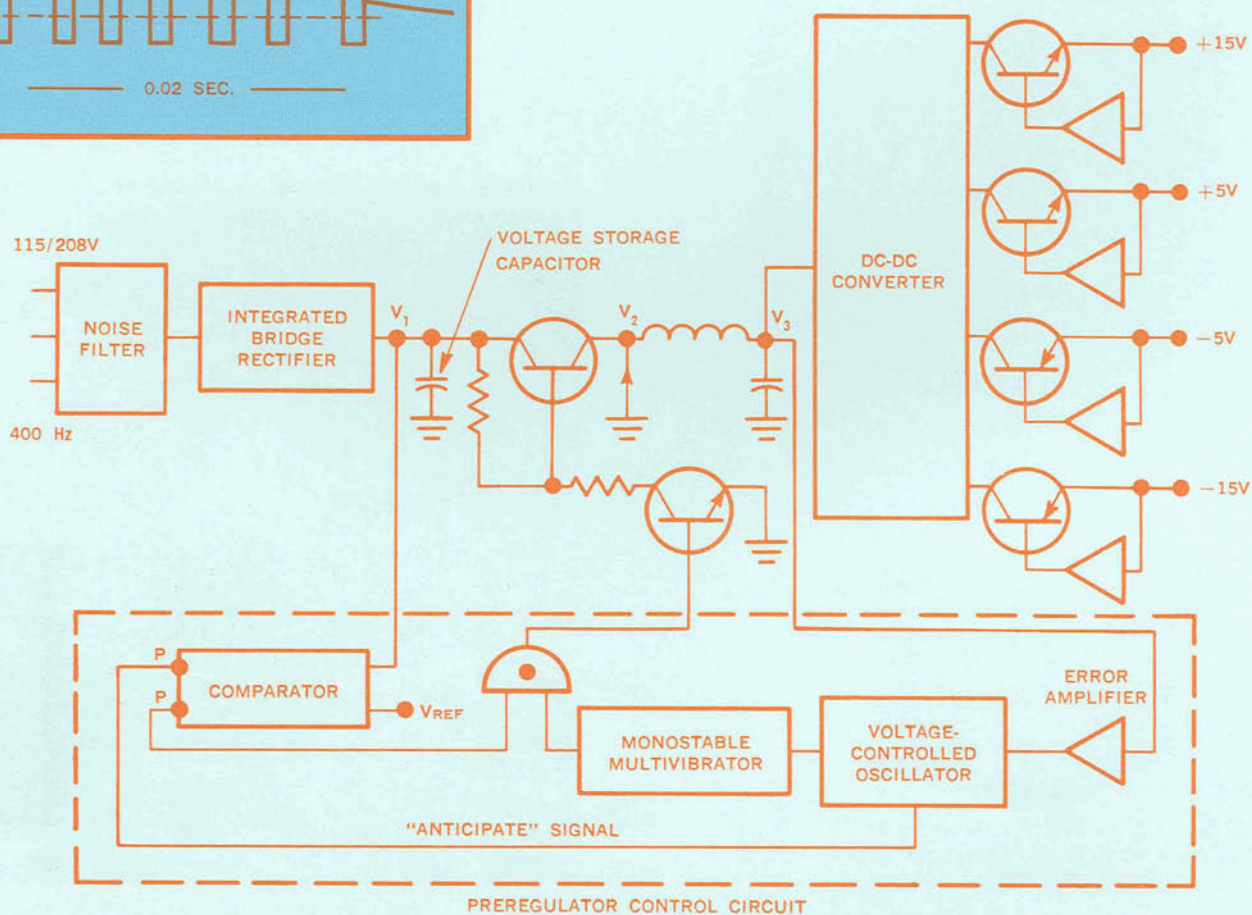

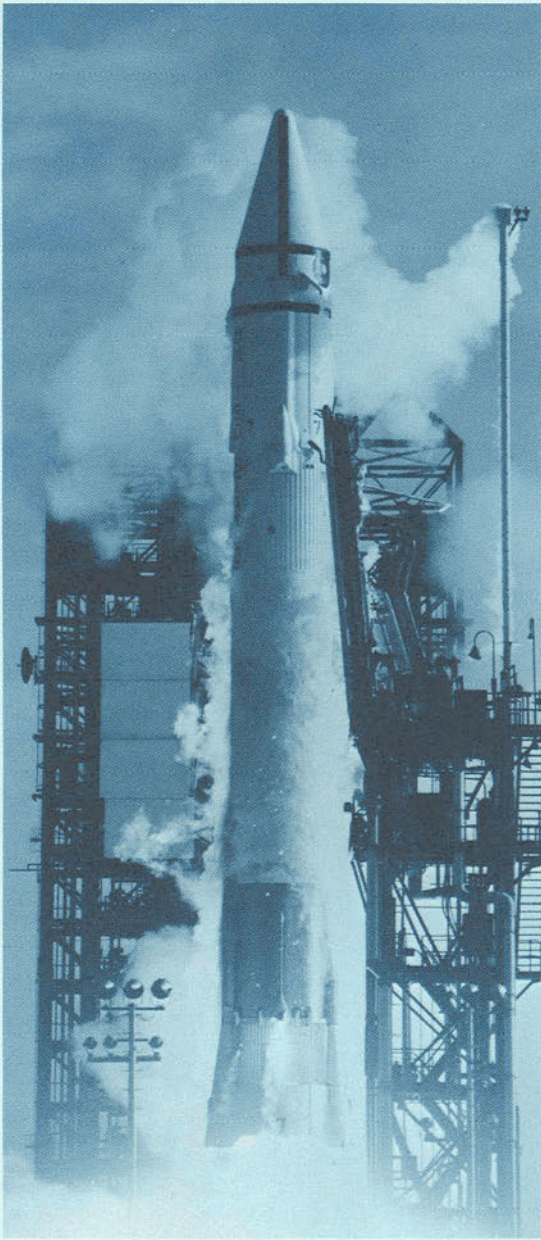

GPK-33

Atlas/Centaur

Navigation

Computer

An outgrowth of Kearfott's earlier L-31 computer (the first general-purpose computer ever to operate in earth orbit) the GPK 33 is a tiny typewriter-sized, solid-state electronic, magnetic drum memory, digital machine having an independently programmable high-speed incremental section — the Sigmator — a real-time integrator which sums, stores, and processes high-frequency incremental inputs from external sources. Employed as the "nerve center" for the Atlas-Centaur booster which successfully launched the Surveyor space-craft on its moon journey.

GPK-33 computer installed on Centaur booster is circled

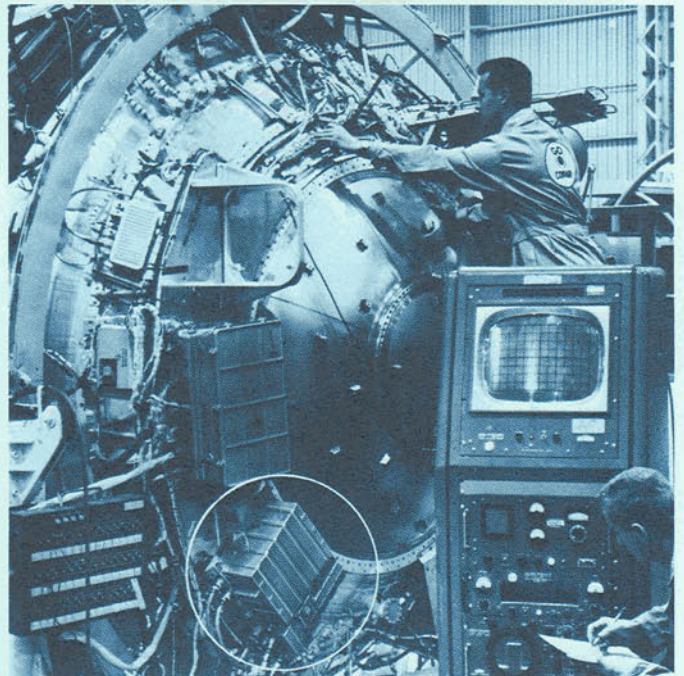

FEATURES

- **Pre-Launch Functions** • Guidance program stored in memory • Computes and provides gyro drift trim coefficients • Computes and provides accelerometer bias and scale factor coefficients • Determines and provides inertial platform final alignment
- **In-Flight Functions** • Calculates vehicle velocity and position information • Calculates and provides steering signals • Calculates engine cut-off and re-ignition signals • Determines coast phase duration • Shuts down its own power-consuming components during long coast periods, restarts when needed • Generates signals steering Atlas-Centaur booster away from Surveyor after separation • Telemetry data output

CHARACTERISTICS

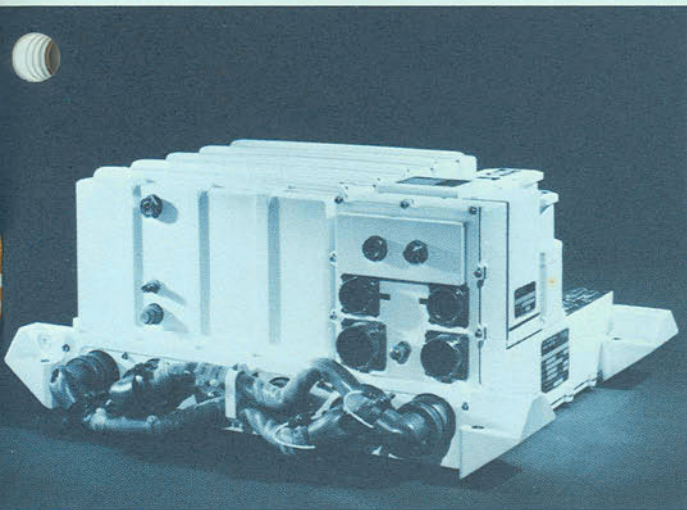

| | |
|-------------------------|--|
| Type | Digital general-purpose synchronous, with Sigmator |
| Number System | Binary, fixed point arithmetic |
| Application | Missile inertial guidance computations |
| Operation | Serial, 160 KHz clock frequency |
| Memory | 3456 X 25 bit words (10% set aside for temporary storage of in-flight data) |
| Word Format | |
| Length | 25 bits |
| Operands | 24 bits and sign |
| Negative | 2's complement |
| Instruction | Dual address |
| Input/Output (Sigmator) | Asynchronous pulse inputs and outputs, telemetry, and time countdown. Provision for A/D and D/A conversion, parallel or serial discrete inputs and outputs |
| Digital Input Channels | 3 pulse rates, 7 discrete inputs |
| Digital Output Channels | 15 discrete outputs, 1 serial data output |
| A/D Conversion | 6 channels, electromechanical |

ε 6 μs

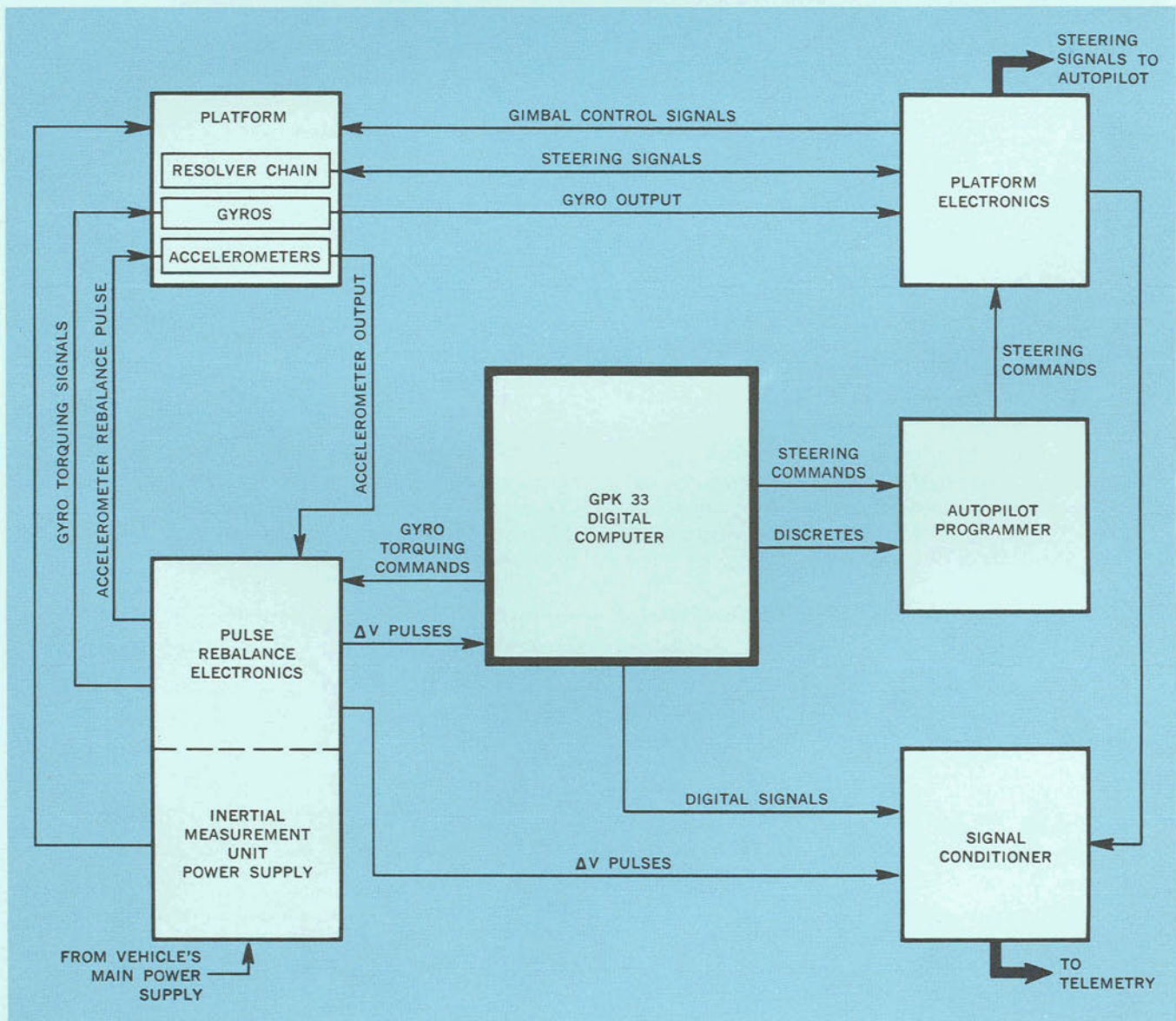

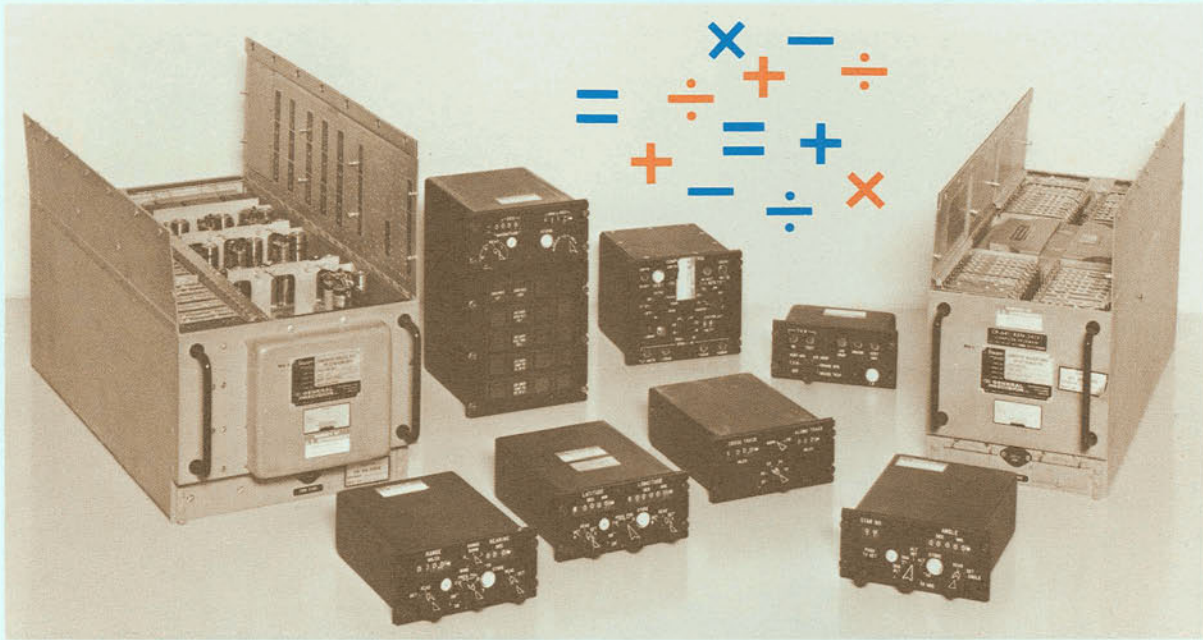

A general-purpose digital computer system performing complex real-time computing and control operations, this Kearfott-designed equipment, originally produced for automatic navigation in the C-141 aircraft, quickly demonstrated its adaptability to other applications including space guidance and control as the GPK-33.

Consisting of a compact general-purpose computer, control and display elements, input/output equipment signal conditioners, and power supplies, this system logically processes multiple inputs systematically and in a time-span that is virtually instantaneous to produce outputs useable as automatic control signals or as easily interpreted visual data.

Inherent flexibility of design readily accommodates computational and growth changes through use of standardized ground support equipment, and computer compatibility with a wide variety of applications is assured.

Among the many superior features of the general-purpose digital computer unit of the AN/ASN-24(V) is the nature of its programming. With simple techniques, and without any physical modifications, the computer can be programmed to perform an exceptionally large variety of functions. These programs can be quickly altered in the field, when necessary, to account for changes in system hardware, accuracy requirements, or performance parameters.

For each new application of the AN/ASN-24(V), a new program set is assembled from the existing library of routines. This set is especially tailored to produce the prescribed solutions, with prescribed accuracies, as called for by the system equations. After a program has been composed, tested, and fielded, it will be used frequently. Thus, special care is taken to develop it to a state of high efficiency in terms of both solution rate and utilization of memory space.

AN/ASN-24(v)

Airborne/Aerospace Computer Set

CHARACTERISTICS (Basic System)

| | |
|---|---|
| Weight (includes computer, converter chassis, power supply, set control, Lat-Lon range bearing along/cross track, and celestial data control indicators): 111.3 lbs. | |
| Volume (entire system): | 1.9 cu. ft. |
| Pulse Input Channels: | 4 |
| Power Requirements: | 115 volts, 400 Hz, 3 phase, 368 watts 28 volts dc, 33 watts 5 volts, ac/dc, 6.5 watts 26 volts, 400 Hz, 16 watts |
| Environment: Temperature, Humidity, Vibration Altitude Cooling | Per MIL-E-5400, Class 2 Sea Level to 70,000 ft. Forced air (ARINC 404) |
| Configurations: Present position, ground velocity, wind velocity, course and distance, along-track, cross-track, air drop, vertical navigation, and general navigation | |
| Drum Memory Capacity: Drum Memory Permanent Storage Capacity: Drum Memory Temporary Storage Capacity: Sigmator Section: Timing and Arithmetic Registers: Clock Frequency: Word Time: Operand Format: | 99,600 bits, 6000 rpm 60 tracks, 3840 words 4 tracks, 256 words 2 tracks 4 tracks 160 KHz 156.25 microsec Fixed-point, 25 bits, 2's complement |
| Instruction Format: one + one address operation code operand address next instruction address | 25 bits 3 bits 11 bits 11 bits |
| A/D Conversion: | Up to 18 servo modules (electromechanical) |
| Displays: Latitude, longitude, range, bearing, cross-track, along-track, wind direction, wind speed, celestial angle, air drop, cruise control, and vertical navigation | |
| Applicable Specifications: | MIL-C-27618, MIL-C-6781B, MIL-E-5400E, MIL-I-6181D, MIL-T-5422E, MIL-R-27542, MIL-STD-704, ARINC 404, ARINC 407-1 |

FEATURES — • Compact, lightweight, accurate synchronous binary digital GP computer design • Centralized digital computation — processes thousands of calculations, decisions, commands per second • Self-checking • Versatile, flexible for growth potential • Easily installed and maintained • Has magnetic drum memory and an independent programmable high-speed incremental integrator • Eight basic orders include ADD, SUBTRACT, MULTIPLY and DIVIDE • Accepts digital signals from self-contained A/D con-

version equipment, control panels, and from pulse inputs • Modularly designed with digital discrete input/output circuit components • Functionally flexible — performance proved over long-term WADC evaluation • Officially recommended as standard "off-the-shelf" computer hardware • Self-contained power supply • Quickly, easily modified for Transport aircraft, Reconnaissance/Strike aircraft, missile, booster, spacecraft, VTOL/STOL aircraft, attack weapons control, camera control, and many other possible applications.

TYPICAL APPLICATIONS AND VARIATIONS

C-141A LOGISTICS TRANSPORT APPLICATION • Computes, displays aircraft position from heading data, air data computer and Doppler • TACAN, LORAN, sextant, and radar inputs update position • Furnishes continuous flight information on range-to-go, destination bearing, wind speed, ground speed, ground track, present position, along-track and cross-track deviations, air drop, climb and descent

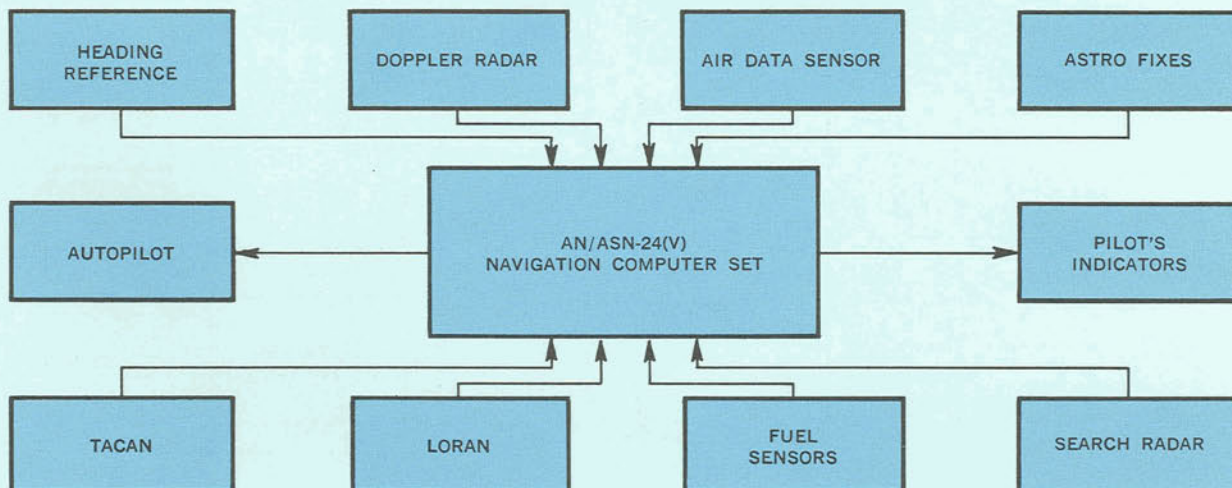

665A RECONNAISSANCE/STRIKE APPLICATION

Provides efficient, accurate control of the reconnaissance sensors' film recorder drive mechanisms and makes available the best possible position and heading data for both in-flight processing and postflight analyses. Inputs include Doppler radar ground speed and drift angle, true air speed, pressure altitude, gyroscope heading, magnetic heading, radar altitude, TACAN bearing and range, navigation radar bearing and range, and LORAN time differences. The AN/ASN-24(V) accurately computes and displays present position, ground speed, wind velocity, true ground track, and course and distance (without latitude and longitude restrictions).

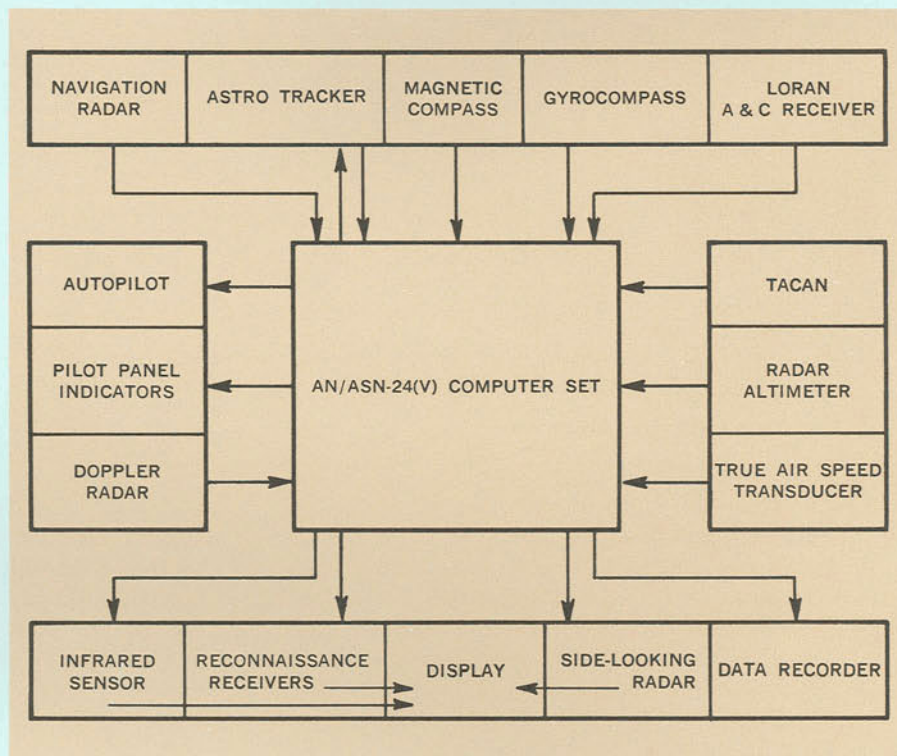

ADVANCED ARMY AIR- CRAFT INSTRUMENTATION SYSTEM APPLICATION

In this application, the AN/ASN-24(V) is a computing center for aircraft using navigation sensor inputs for map-type displays. It displays altitude, direction, flight path, and speed vertically and aircraft's running navigational plot of terrain track horizontally on cathode ray tube indicators. Data processing and computation for the entire system are performed by the AN/ASN-24(V) digital computer. These functions include the following: vertical display symbol displacement commands, horizontal display symbol displacement commands, navigation computations, and fuel management computations.

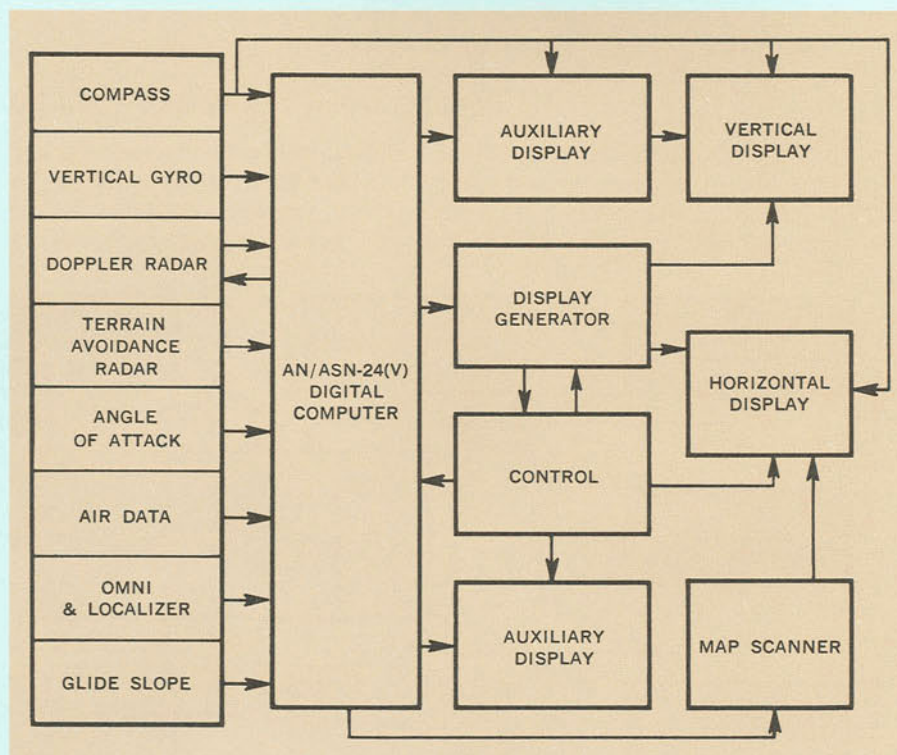

DIGITAL CAMERA CONTROL SYSTEM APPLICATION

This high-speed system uses an AN/ASN-24 computer to control three basic functions: image-motion compensation, exposure, and cycling rate. Among the fixed and variable sensor-data inputs are ground speed, altitude, and amount of reflected light from the terrain below. It adjusts image-motion compensation with extreme accuracy, and it regulates exposure by computing and controlling camera shutter speeds and diaphragm openings. In addition, it adjusts control of cycling rate to provide any required overlap for photos taken in a series. It can be operated automatically or semiautomatically and can be adapted to control the most advanced aerial cameras.

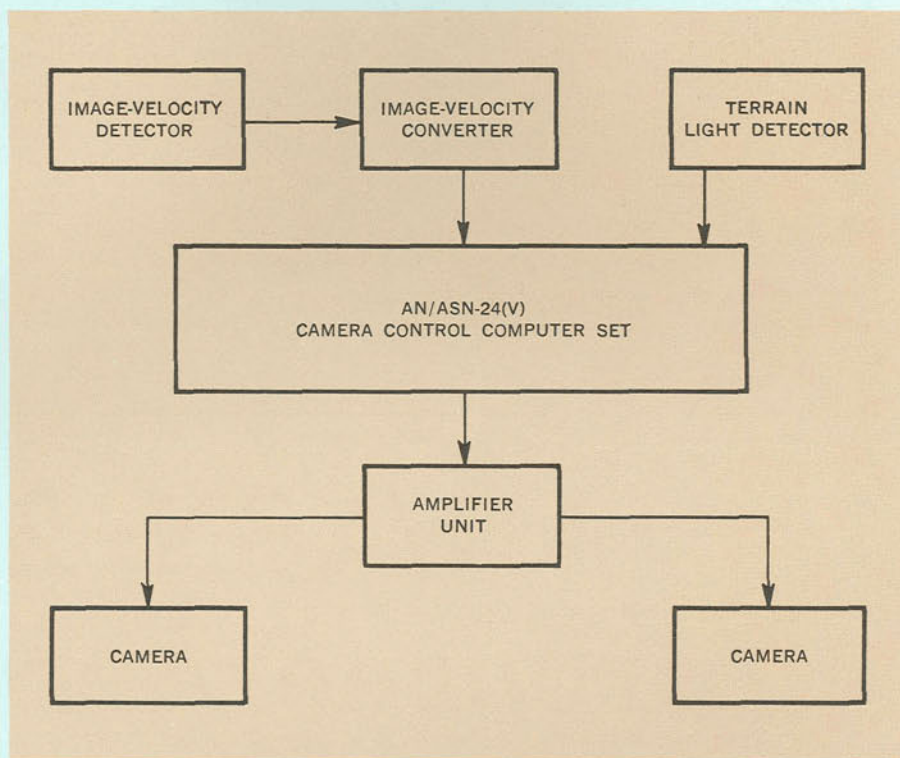

POTENTIAL APPLICATIONS FOR AN/ASN-24(V)

VTOL/STOL AIRCRAFT NAVIGATION SYSTEM

In this application, the AN/ASN-24(V) could not only execute general-purpose navigation functions, but it could also maintain tight, precise control over vertical take-off and landing maneuvers. The system is suitable for helicopter control and for servicing of high-performance aircraft systems.

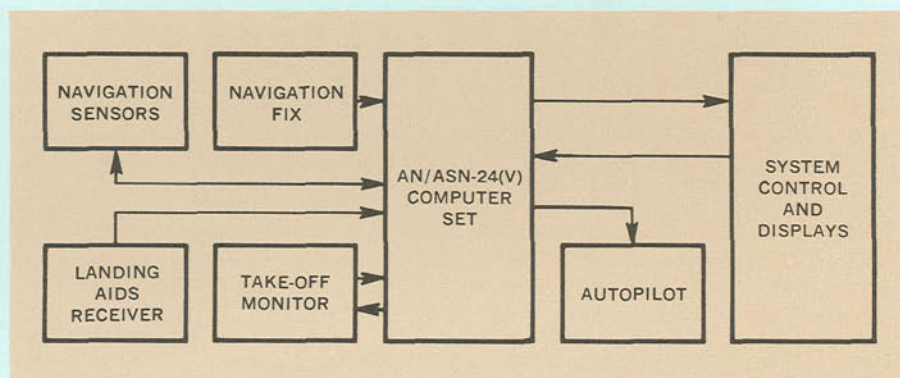

ASTRO-INERTIAL DIGITAL DOPPLER SYSTEM

Used at full capacity, this high precision system could accurately define aircraft position anywhere in the world for unlimited periods. It could be applied in virtually all possible missions in any type of aircraft. Lightweight and simple, it would consist of presently available, fully-improved units.

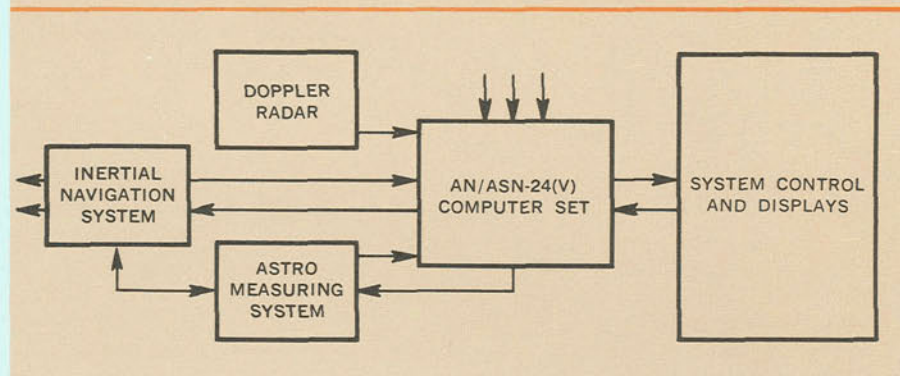

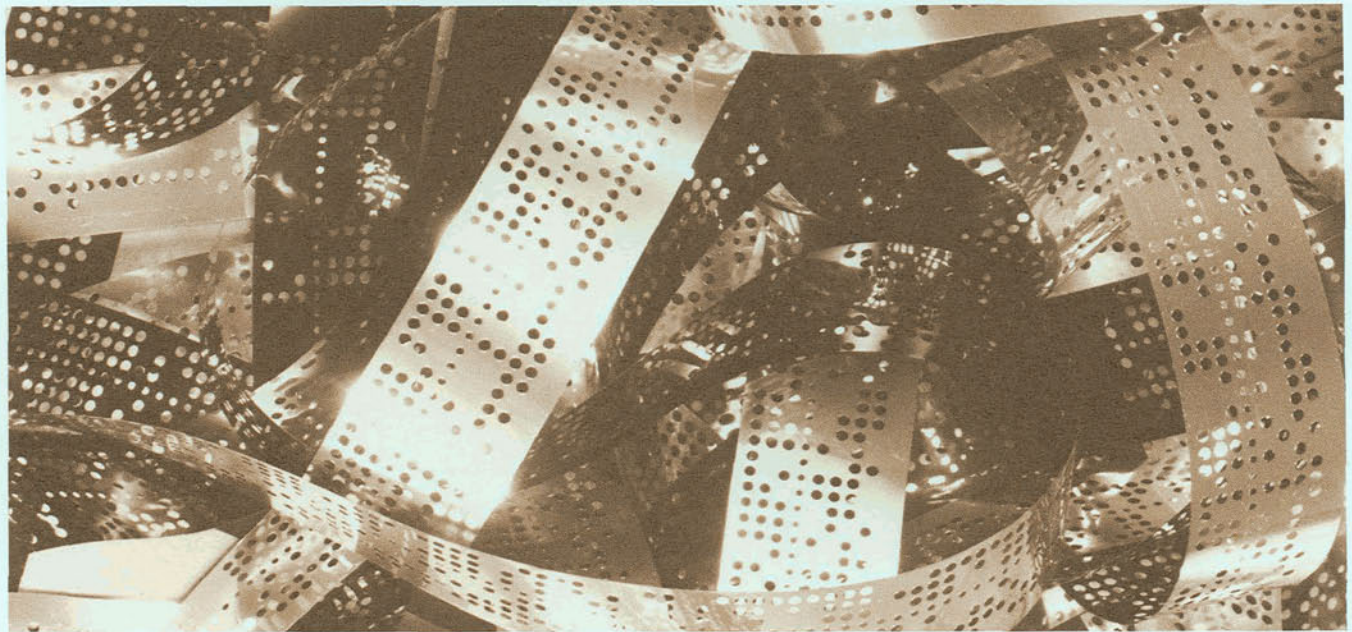

AN/ASN-24(G) Airborne/Aerospace Computer Set

The AN/ASN-24(G) general-purpose digital computer set is the natural follow-on to its highly successful forerunner, the AN/ASN-24(V) which, by early 1966, logged more than 30,000 hours of flight operating time aboard the Air Force transport giant — the C-141 aircraft. The AN/ASN-24(V) has been updated, improved, and value-engineered to result in this new configuration. AN/ASN-24(G) represents a major improvement in performance while retaining commonality with existing AN/ASN-24(V) inventory.

The major changes are in a 50% increase in memory capacity and clock rate. Based on these improvements, it has the expanded capability to meet the demands of airborne navigation, flight management, and airborne data processing required in today's ever changing technology. This new system was developed based on the extensive testing and flight experience of the AN/ASN-24(V) in many different aircraft, in every latitude, and with hundreds of operators. It has been designed to fit the same mounting racks, to use test equipment,

handbooks, and maintenance procedures, and the same production assembly lines and equipment that are used for the AN/ASN-24(V).

The AN/ASN-24(G) computer set consists of the GPK-50 general-purpose digital computer, console-mounted control and display units, input-output equipment, signal conditioners, and power supplies.

In operation, the AN/ASN-24(G) accepts multiple, varied inputs, processes the data logically and systematically, and almost instantaneously. The resulting computed data is simple and straightforward — whether as signals to automatic controls or as data the operator can easily interpret and use.

The 50% improvement in the capacity and speed of the AN/ASN-24(G) is obtained by increasing the density of the binary digits packed upon the surface of the rotating memory drum. The new memory drum will be physically interchangeable with the AN/ASN-24(V) drum but the bits will be spaced 50% closer together.

Since the speed of the AN/ASN-24(G) has been increased by 50%, the time available to interpret a signal from a read head or to impress a signal from a write head upon the drum, has decreased correspondingly. Extensive testing has proven that the logic as originally designed, without changes, is fully able to cope with this situation and retain a wide margin of safety. In other cases, minor components (resistors, capacitors, etc.) have been changed to meet the demands for different time constants, response characteristics, and signal levels. A high degree of commonality between the AN/ASN-24(V) and the AN/ASN-24(G) has, nevertheless, been retained, and logic cards manufactured for the AN/ASN-24(G) will continue to be compatible with the AN/ASN-24(V).

Improvements in almost every routine have been achieved including: DEAD RECKONING ROUTINE — made more accurate, while decreasing program computation time by more than 50%. TACAN FIX ROUTINE — accuracy and frequency increased. LORAN FIX ROUTINE — fully converged two-position-line fixes available several times per minute, with optimization to take into account angle of cut of position-lines. RADAR FIXING — fully tracking radar cross-hairs available, with automatic correction of heading with Doppler available or wind with Doppler invalid.

BEST AVAILABLE TRUE HEADING — continuous checking of compass systems to warn operator of unreliable compass operation. Capability of using magnetic headings in polar latitudes. Full capability of using heading corrections established by celestial, radar or manual means. Compass averaging maintained when more than one compass in use, with both in magnetically slaved mode. Gyro drift rate automatically computed if a celestial heading check is available.

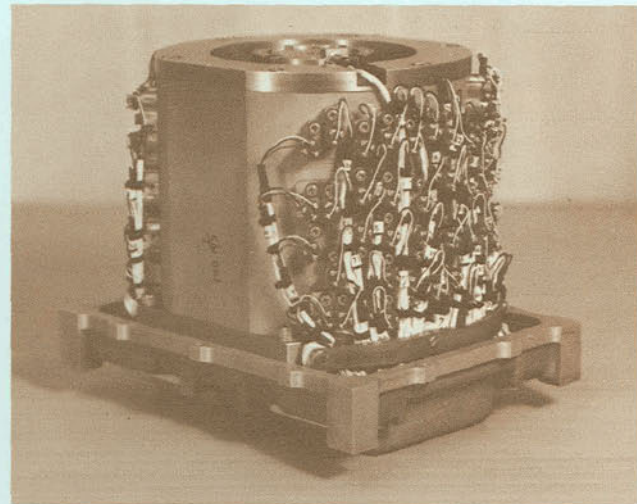

FIX-MONITORED AZIMUTH — heading corrections available from TACAN, LORAN, or manual fixes. WIND BETWEEN FIXES — wind available from fixes even when aircraft is orbiting, providing an aid such as TACAN, LORAN, or radar is available. POLAR COMPUTATIONS — 50% decrease in computation time, with enhanced accuracy. READOUTS — all readouts updated as fast as the human eye can follow, and up to every 1/100 second if required.

GPK-50 DIGITAL COMPUTER — The versatile GPK-50 Digital Computer of the AN/ASN-24(G) Computer Set features two-stored-program sections which operate concurrently: a general-purpose section which performs the add, subtract, multiply and divide functions; and a "Sigmat" section for such operations as high-speed integration. Both sections use the same magnetic memory drum for instruction and data storage, and general-purpose program controls data transfers between them.

CHARACTERISTICS

| | |
|--|---|
| Weight (entire system): | 124.7 lbs. |
| Volume (entire system): | 2.128 cu. ft. |
| Pulse Input Channels: | 4 |
| Power Requirements: | 115 volts, 400 Hz, 3 phase, 368 watts; 28 volts dc, 33 watts; 5 volts ac/dc, 6.5 watts; 26 volts, 400 Hz, 16 watts. |
| Environment: Temperature, Humidity, Vibration Altitude Cooling Shock | Per MIL-E-5400, Class 2 Sea level to 70,000 ft. Forced air (ARINC 404) RTCA 120-61/DO-108 |
| Drum Memory Capacity: | 168,000 bits, 6000 rpm |
| Drum Memory Permanent Storage Capacity: | 60 tracks, 5760 words |
| Drum Memory Temporary Storage Capacity: | 4 tracks, 296 words |
| Sigmat Section: | 2 tracks |
| Timing Registers: | 4 tracks |
| Clock Frequency: | 240 KHz |
| Word Time: | 104.17 μ sec. |
| Operand Format: | Fixed point, 25 bits (equals 7 decimals), 2's complement |
| Instruction Format: one + one address operation code operand address next instruction address | 25 bits 3 bits 11 bits 11 bits |
| Mode of Operation: | Serial, synchronous, binary |
| Displays: | Latitude, longitude, range, bearing, cross-track, along-track, wind direction, wind speed, celestial angle, air drop, cruise control, and vertical navigation |



L-90 Series General-Purpose Digital Computers

Applicable as navigational, guidance, control, command, weapons delivery, reconnaissance, surveillance data processing, or central flight management computers, L-90 class machines offer speed, accuracy, reliability, and versatility in aircraft, missile, and spacecraft systems. L90-1 and L90-3 models use integrated microcircuits contributing significantly to reduction in both number of components and external connections, and incorporate advanced solid state A/D and D/A converters which can interface with a variety of sensors.

Flexible in design, computers in this series can function with a variety of memory types and sizes, a feature permitting memory capacity expansion with no change in computer logic.

FEATURES



- Small, lightweight
- Few parts, modular design
- Superior speed and precision
- Reliable
- Flexible memory and input-output interfaces
- Successfully flight tested at Holloman AFB
- Wide range of applications, including — Navigation, guidance, control, spaceborne command post, airborne ASW data collating and processing
- Available with extensive software programming aids including — Simulator program compatible with IBM7090, utility, checkout routines and subroutines, NELIAC compiler, assembly system

CHARACTERISTICS

| | L90-1 | L90-3 |
|-------------------------|--|--|
| Typical Computations | Doppler navigation with TACAN, LORAN Inertial navigation Weapons control General navigation Airborne data processing | Doppler/inertial with or without radio aids Vehicle guidance/control Airborne data collection and processing Subsystem fault monitoring |
| Computer Type | General-purpose, whole number | General-purpose, whole number |
| Number System | Binary, fixed-point arithmetic | Binary, fixed-point arithmetic |
| Operation | Serial | Semi-serial |
| Clock Rate | 5 MHz | 5 MHz |
| Circuitry | Silicon planar epitaxial semiconductor integrated circuits | |
| Memory Type | Ferrite Core | Ferrite core or thin film |
| Memory Capacity | 4096 X 28 bits expandable to 16,384 X 28 bits, parallel organized, non-volatile, 4.6 μ sec/cycle, 1 μ sec access | 8192 X 28 bits expandable to 16,384 X 28 bits, parallel organized, non-volatile, 2.4 μ sec/cycle |
| Word Format | 27 bits + sign. 28-bit data word. Two 14-bit instructions per memory word. 5-bit operation code | |
| Digital Input Channels | 32 discrete inputs expandable to 64; 2 parallel inputs expandable to any requirement; 64 serial input channels available. | 2 parallel inputs; 64 discrete inputs; 6 pulse input channels; direct external memory access; serial channels as required. |
| Digital Output Channels | 2 parallel output words, expandable to any requirement; 4 pulse output channels; 16 discrete output channels expandable to 128; 1 channel serial data input. | 2 parallel outputs; 32 discrete outputs; 4 pulse output channels; 1 serial data channel. |
| Power Supply | External | External |
| Power Consumption | 50 watts | 100 watts |
| Operation Times | ADD: 8.4 μ sec MULTIPLY: 86.8 μ sec DIVIDE: 165.2 μ sec | ADD: 3.3 μ sec MULTIPLY: 41.1 μ sec DIVIDE: 43.4 μ sec SQ. ROOT: 41.1 μ sec |
| Weight | 35 lbs. | 35 lbs. |
| Size | 0.5 cu. ft. | 0.5 cu. ft. |



reiteration

Recognized Kearfott computer competence has established a sound reputation for advanced equipment that is unmatched for precision, quality, and reliability. The logical choice for small, versatile digital computers tailored to airborne and space applications, Kearfott continues its progressive development to produce computing equipment that is superior to any obtainable. Imaginative concepts, novel adaptations, and engineering excellence combine to provide computers and displays for virtually any purpose, **including —**



- Missile and aircraft navigation, guidance, command, and control
- Logistic transport aircraft position, distance to-go, destination, bearing ground track, ground speed, track deviation, airdrop, climb and descent
- Recon/Strike aircraft camera control, heading, position, ground speed, ground track, wind speed, course, and distance
- Fixed or rotary wing aircraft computing center for altitude, direction flight path, vertical and horizontal speed, fuel management
- Attack aircraft navigation and weapons delivery
- V/STOL aircraft navigation and control
- Missile pre-launch and in-flight functions
- Spacecraft central navigation, guidance, and data processing

— And if Kearfott computers *such as:*

- GPK-20
- GPK-10
- AN/ASN-24 (V)
- L90-1
- MICRO-MINAC
- GPK-33
- GPK-50[AN/ASN-24 (G)]
- L90-3

— *do not answer* specific requirements for a particular application, just program Kearfott into the loop. It's the easiest solution for computers going somewhere.

SALES
OFFICES

Wayne, N. J.

Dallas, Texas

Seattle, Wash.

Dayton, Ohio

Webster, Texas

Huntsville, Ala.

Cleveland, Ohio

Palo Alto, Calif.

Little Falls, N. J.

Oakbrook, Illinois

Washington, D. C.

Los Angeles, Calif.

Clearwater, Florida

Wellesley Hills, Mass.

GENERAL PRECISION, INC., IS A SUBSIDIARY OF GENERAL PRECISION EQUIPMENT CORPORATION.

H. PECK

1940 S. FIGLIERAN